



eLink 100 HDMI Wireless Extender



Safety Instructions

Safety Instructions • English

⚠ WARNING: This symbol, , when used on the product, is intended to alert the user of the presence of uninsulated dangerous voltage within the product's enclosure that may present a risk of electric shock.

ATTENTION: This symbol, , when used on the product, is intended to alert the user of important operating and maintenance (servicing) instructions in the literature provided with the equipment.

For information on safety guidelines, regulatory compliances, EMI/EMF compatibility, accessibility, and related topics, see the Extron Safety and Regulatory Compliance Guide, part number 68-290-01, on the Extron website, www.extron.com.

Sicherheitsanweisungen • Deutsch

WARNUNG: Dieses Symbol , auf dem Produkt soll den Benutzer darauf aufmerksam machen, dass im Inneren des Gehäuses dieses Produktes gefährliche Spannungen herrschen, die nicht isoliert sind und die einen elektrischen Schlag verursachen können.

VORSICHT: Dieses Symbol , auf dem Produkt soll dem Benutzer in der im Lieferumfang enthaltenen Dokumentation besonders wichtige Hinweise zur Bedienung und Wartung (Instandhaltung) geben.

Weitere Informationen über die Sicherheitsrichtlinien, Produkthandhabung, EMI/EMF-Kompatibilität, Zugänglichkeit und verwandte Themen finden Sie in den Extron-Richtlinien für Sicherheit und Handhabung (Artikelnummer 68-290-01) auf der Extron-Website, www.extron.com.

Instrucciones de seguridad • Español

ADVERTENCIA: Este símbolo, , cuando se utiliza en el producto, avisa al usuario de la presencia de voltaje peligroso sin aislar dentro del producto, lo que puede representar un riesgo de descarga eléctrica.

ATENCIÓN: Este símbolo, , cuando se utiliza en el producto, avisa al usuario de la presencia de importantes instrucciones de uso y mantenimiento recogidas en la documentación proporcionada con el equipo.

Para obtener información sobre directrices de seguridad, cumplimiento de normativas, compatibilidad electromagnética, accesibilidad y temas relacionados, consulte la Guía de cumplimiento de normativas y seguridad de Extron, referencia 68-290-01, en el sitio Web de Extron, www.extron.com.

Instructions de sécurité • Français

AVERTISSEMENT : Ce pictogramme, , lorsqu'il est utilisé sur le produit, signale à l'utilisateur la présence à l'intérieur du boîtier du produit d'une tension électrique dangereuse susceptible de provoquer un choc électrique.

ATTENTION : Ce pictogramme, , lorsqu'il est utilisé sur le produit, signale à l'utilisateur des instructions d'utilisation ou de maintenance importantes qui se trouvent dans la documentation fournie avec le matériel.

Pour en savoir plus sur les règles de sécurité, la conformité à la réglementation, la compatibilité EMI/EMF, l'accessibilité, et autres sujets connexes, lisez les informations de sécurité et de conformité Extron, réf. 68-290-01, sur le site Extron, www.extron.com.

Istruzioni di sicurezza • Italiano

AVVERTENZA: Il simbolo, , se usato sul prodotto, serve ad avvertire l'utente della presenza di tensione non isolata pericolosa all'interno del contenitore del prodotto che può costituire un rischio di scosse elettriche.

ATTENZIONE: Il simbolo, , se usato sul prodotto, serve ad avvertire l'utente della presenza di importanti istruzioni di funzionamento e manutenzione nella documentazione fornita con l'apparecchio.

Per informazioni su parametri di sicurezza, conformità alle normative, compatibilità EMI/EMF, accessibilità e argomenti simili, fare riferimento alla Guida alla conformità normativa e di sicurezza di Extron, cod. articolo 68-290-01, sul sito web di Extron, www.extron.com.

Instrukcje bezpieczeństwa • Polska

OSTRZEŻENIE: Ten symbol, , gdy używany na produkt, ma na celu poinformować użytkownika o obecności izolowanego i niebezpiecznego napięcia wewnątrz obudowy produktu, który może stanowić zagrożenie porażenia prądem elektrycznym.

UWAGI: Ten symbol, , gdy używany na produkt, jest przeznaczony do ostrzegania użytkownika ważne operacyjne oraz instrukcje konserwacji (obsługi) w literaturze, wyposażone w sprzęt.

Informacji na temat wytycznych w sprawie bezpieczeństwa, regulacji wzajemnej zgodności, zgodność EMI/EMF, dostępności i Tematy pokrewne, zobacz Extron bezpieczeństwa i regulacyjnego zgodności przewodnik, część numer 68-290-01, na stronie internetowej Extron, www.extron.com.

Инструкция по технике безопасности • Русский

ПРЕДУПРЕЖДЕНИЕ: Данный символ, , если указан на продукте, предупреждает пользователя о наличии неизолированного опасного напряжения внутри корпуса продукта, которое может привести к поражению электрическим током.

ВНИМАНИЕ: Данный символ, , если указан на продукте, предупреждает пользователя о наличии важных инструкций по эксплуатации и обслуживанию в руководстве, прилагаемом к данному оборудованию.

Для получения информации о правилах техники безопасности, соблюдении нормативных требований, электромагнитной совместимости (ЭМП/ЭДС), возможности доступа и других вопросах см. руководство по безопасности и соблюдению нормативных требований Extron на сайте Extron: www.extron.com, номер по каталогу - 68-290-01.

安全说明 • 简体中文

警告: 产品上的这个标志意在警告用户该产品机壳内有暴露的危险电压, 有触电危险。

注意: 产品上的这个标志意在提示用户设备随附的用户手册中有重要的操作和维护(维修)说明。

关于我们产品的安全指南、遵循的规范、EMI/EMF的兼容性、无障碍使用的特性等相关内容, 敬请访问 Extron 网站, www.extron.com, 参见 Extron 安全规范指南, 产品编号 68-290-01。

安全記事・繁體中文

警告: ⚠️ 若產品上使用此符號，是為了提醒使用者，產品機殼內存在著可能會導致觸電之風險的未絕緣危險電壓。

注意 ⚠️ 若產品上使用此符號，是為了提醒使用者，設備隨附的用戶手冊中有重要的操作和維護(維修)說明。

有關安全性指導方針、法規遵守、EMI/EMF 相容性、存取範圍和相關主題的詳細資訊，請瀏覽 Extron 網站: www.extron.com，然後參閱《Extron 安全性與法規遵守手冊》，準則編號 68-290-01。

安全上のご注意・日本語

警告: この記号 ⚠️ が製品上に表示されている場合は、筐体内に絶縁されていない高電圧が流れ、感電の危険があることを示しています。

注意: この記号 ⚠️ が製品上に表示されている場合は、本機の取扱説明書に記載されている重要な操作と保守(整備)の指示についてユーザーの注意を喚起するものです。

安全上のご注意、法規遵守、EMI/EMF適合性、その他の関連項目については、エクストロンのウェブサイト www.extron.com より「Extron Safety and Regulatory Compliance Guide」(P/N 68-290-01) をご覧ください。

안전 지침・한국어

경고: 이 기호 ⚠️ 가 제품에 사용될 경우, 제품의 인클로저 내에 있는 접지되지 않은 위험한 전류로 인해 사용자가 감전될 위험이 있음을 경고합니다.

주의: 이 기호 ⚠️ 가 제품에 사용될 경우, 장비와 함께 제공된 책자에 나와 있는 주요 운영 및 유지보수(정비) 지침을 경고합니다.

안전 가이드라인, 규제 준수, EMI/EMF 호환성, 접근성, 그리고 관련 항목에 대한 자세한 내용은 Extron 웹 사이트(www.extron.com)의 Extron 안전 및 규제 준수 안내서, 68-290-01 조항을 참조하십시오.

Copyright

© 2014-2019 Extron Electronics. All rights reserved. www.extron.com

Trademarks

All trademarks mentioned in this guide are the properties of their respective owners.

The following registered trademarks (®), registered service marks (SM), and trademarks (TM) are the property of RGB Systems, Inc. or Extron Electronics (see the current list of trademarks on the [Terms of Use](#) page at www.extron.com):

Registered Trademarks (®)

Extron, Cable Cubby, ControlScript, CrossPoint, DTP, eBUS, EDID Manager, EDID Minder, Flat Field, FlexOS, Glitch Free, Global Configurator, Global Scriptor, GlobalViewer, Hideaway, HyperLane, IP Intercom, IP Link, Key Minder, LinkLicense, LockIt, MediaLink, MediaPort, NetPA, PlenumVault, PoleVault, PowerCage, PURE3, Quantum, Show Me, SoundField, SpeedMount, SpeedSwitch, StudioStation, System *INTEGRATOR*, TeamWork, TouchLink, V-Lock, VideoLounge, VN-Matrix, VoiceLift, WallVault, WindoWall, XTP, XTP Systems, and ZipClip

Registered Service Mark (SM): S3 Service Support Solutions

Trademarks (TM)

AAP, AFL (Accu-Rate Frame Lock), ADSP (Advanced Digital Sync Processing), Auto-Image, CableCover, CDRS (Class D Ripple Suppression), Codec Connect, DDSP (Digital Display Sync Processing), DMI (Dynamic Motion Interpolation), Driver Configurator, DSP Configurator, DSVP (Digital Sync Validation Processing), eLink, EQIP, Everlast, FastBite, FOX, FOXBOX, IP Intercom HelpDesk, MAAP, MicroDigital, Opti-Torque, PendantConnect, ProDSP, QS-FPC (QuickSwitch Front Panel Controller), Room Agent, Scope-Trigger, ShareLink, SIS, Simple Instruction Set, Skew-Free, SpeedNav, Triple-Action Switching, True4K, Vector™ 4K, WebShare, XTRA, and ZipCaddy

FCC Class B Notice

NOTE: This device complies with part 15 of the FCC rules. Operation is subject to the following two conditions: (1) This device may not cause harmful interference, and (2) This device must accept any interference received, including interference that may cause undesired operation.

This equipment has been tested and found to comply with the limits for a Class B digital device, pursuant to part 15 of the FCC rules. These limits provide reasonable protection against harmful interference in a residential installation. This equipment generates, uses, and can radiate radio frequency energy and, if not installed and used in accordance with the instructions, may cause harmful interference to radio communications. There is no guarantee that interference will not occur. If this equipment does cause interference to radio or television reception, which can be determined by turning the equipment off and on, you are encouraged to try to correct the interference by one or more of the following measures:

- Reorient or relocate the receiving antenna.
- Increase the separation between the equipment and receiver.
- Connect the equipment into an outlet on a circuit different from that to which the receiver is connected.
- Consult the dealer or an experienced radio/TV technician for help.

In order to maintain compliance with FCC regulations, shielded cables must be used with this equipment. Operation with non-approved equipment or unshielded cables is likely to result in interference to radio and TV reception. The user is cautioned that changes and modifications made to the equipment without the approval of the manufacturer could void the user's authority to operate this equipment.

This Class B digital apparatus complies with Canadian ICES-003.

Cet appareil numérique de la classe B est conforme à la norme NMB-003 du Canada.

ATTENTION:

- This equipment complies with FCC radiation exposure limits set forth for an uncontrolled environment. This equipment should be installed and operated with minimum distance 20 cm (7.9 inches) between the radiator and your body.
- Cet équipement est conforme aux limites de radiation de la FCC établies pour un environnement non géré. Il doit être installé et contrôlé à une distance minimale de 20 cm (7,9 inches) entre le radiateur et votre corps.

NOTE: For more information on safety guidelines, regulatory compliances, EMI/EMF compatibility, accessibility, and related topics see the "[Extron Safety and Regulatory Compliance Guide](#)" on the Extron website.

Safety Notices

USA—FCC and FAA

The FCC with its action in ET Docket 96-8 has adopted a safety standard for human exposure to radio frequency (RF) electromagnetic energy emitted by FCC certified equipment. The unit meets the Human Exposure limits found in OET Bulletin 65, supplement C, 2001, and ANSI/IEEE C95.1, 1992. Proper operation of this radio according to the instructions found in this manual will result in exposure substantially below the FCC's recommended limits.

ATTENTION: Due to the fact that the frequencies used by 802.11a, 802.11b, 802.11g, and 802.11n wireless LAN devices may not yet be harmonized in all countries, 802.11a, 802.11b, 802.11g, and 802.11n products are designed for use only in specific countries, and are not allowed to be operated in countries other than those of designated use.

As a user of these products, you are responsible for ensuring that the products are used only in the countries for which they were intended and for verifying that they are configured with the correct selection of frequency and channel for the country of use. Any deviation from the permissible power and frequency settings for the country of use is an infringement of national law and may be punished as such.

FCC Radio Frequency Interference Requirements

This device is restricted to indoor use due to its operation in the 5.15 to 5.25 GHz frequency range. FCC requires this product to be used indoors for the frequency range 5.15 to 5.25 GHz to reduce the potential for harmful interference to co-channel Mobile Satellite systems. High power radars are allocated as primary users of the 5.25 to 5.35 GHz and 5.65 to 5.85 GHz bands.

USA—Federal Communications Commission (FCC)

NOTE: The radiated output power of the wireless network device is far below the FCC radio frequency exposure limits. Nevertheless, the unit should be used in such a manner that the potential for human contact during normal operation is minimized. To avoid the possibility of exceeding the FCC radio frequency exposure limits, you should keep a distance of at least 20 cm between you (or any other person in the vicinity) and the antenna that is built into the unit. Details of the authorized configurations can be found at <http://www.fcc.gov/> by entering the FCC ID number on the device.

Security IC Compliance

Canada, Industry Canada (IC) Notices

This Class B digital apparatus complies with Canadian ICES-003 and RSS-210.

ATTENTION:

- When using IEEE 802.11a wireless LAN, this product is restricted to indoor use due to its operation in the 5.15 to 5.25 GHz frequency range. Industry Canada requires this product to be used indoors for the frequency range of 5.15 GHz to 5.25 GHz to reduce the potential for harmful interference to co-channel mobile satellite systems. High power radar is allocated as the primary user of the 5.25 to 5.35 GHz and 5.65 to 5.85 GHz bands. These radar stations can cause interference with and/or damage to this device.
- The maximum allowed antenna gain for use with this device is 6dBi in order to comply with the E.I.R.P limit for the 5.25 to 5.35 and 5.725 to 5.85 GHz frequency range in point-to-point operation.

This device complies with Industry Canada's licence-exempt RSSs. Operation is subject to the following two conditions: (1) this device may not cause interference, and (2) this device must accept any interference, including interference that may cause undesired operation of the device.

Radio Frequency (RF) Exposure Information

To prevent radio interference to the licensed service, this device is intended to be operated indoors and away from windows to provide maximum shielding. Equipment (or its transmit antenna) that is installed outdoors is subject to licensing.

The radiated output power of the Extron Wireless Device is below the Industry Canada (IC) radio frequency exposure limits. The Extron Wireless Device should be used in such a manner such that the potential for human contact during normal operation is minimized.

Extron Unit IC ID: IC: 10862A-EXT60150801

IC Antenna Statement

Under Industry Canada regulations, this radio transmitter may only operate using an antenna of a type and maximum (or lesser) gain approved for the transmitter by Industry Canada. To reduce potential radio interference to other users, the antenna type and its gain should be so chosen that the equivalent isotropically radiated power (e.i.r.p.) is not more than that necessary for successful communication.

This radio transmitter (IC:10862A-EXT60150801) has been approved by Industry Canada to operate with the antenna types listed below with the maximum permissible gain and required antenna impedance for each antenna type indicated. Antenna types not included in this list, having a gain greater than the maximum gain indicated for that type, are strictly prohibited for use with this device.

Type: Dipole

Maximum Peak Gain: 2 dBi

Impedance: 50 Ohm

European Union

The low band 5.15-5.35 GHz is for indoor use only.

Consignes de sécurité :

USA—FCC et FAA

La FCC, par son action dans le dossier ET Docket 96-8, a adopté une norme de sécurité relative à l'exposition humaine à l'énergie électromagnétique des ondes radio (RF), émise par du matériel certifié FCC. L'unité satisfait aux restrictions relatives à l'exposition humaine, énoncées dans le supplément C (2001) du OET Bulletin 65 et dans le standard ANSI/IEEE C95.1 (1992). L'utilisation appropriée de cette radio, conformément aux instructions figurant dans ce manuel, donnera lieu à une exposition nettement inférieure aux limites recommandées par la FCC.

ATTENTION : Compte tenu de l'éventuel manque d'harmonisation des fréquences utilisées par des périphériques LAN sans fil conformes aux standards 802.11a, 802.11b, 802.11g, et 802.11n, les produits 802.11a, 802.11b, 802.11g, et 802.11n peuvent être utilisés uniquement dans certains pays, et ne peuvent fonctionner en dehors des pays dans lesquels leur usage est prévu.

En tant qu'utilisateur de ces produits, vous devez veiller à ce que ces produits soient utilisés uniquement dans les pays dans lesquels leur usage est prévu et vérifier qu'ils soient configurés avec les fréquences et les canaux appropriés, en fonction du pays dans lequel ils sont utilisés. Tout écart aux paramètres de puissance et de fréquence pour le pays d'utilisation constitue une infraction à la législation locale et est passible de sanctions.

Dispositions de la FCC en matière d'interférences électromagnétiques

Cet appareil est limité à une utilisation en intérieur du fait de son fonctionnement dans la bande de fréquences 5,15-5,25 GHz. La FCC exige que ce produit soit utilisé en intérieur pour la bande de fréquences de 5,15-5,25 GHz, afin de réduire les possibilités d'interférences préjudiciables vers des systèmes mobiles par satellite affectant le même canal. Un radar à haute puissance est désigné utilisateur principal des bandes 5,25-5,35 GHz et 5,65-5,85 GHz.

USA—Federal Communications Commission (FCC)

REMARQUE : La puissance de sortie radiée de l'appareil réseau sans fil est nettement inférieure aux restrictions de la FCC en matière d'exposition aux ondes radio. Néanmoins, l'unité devrait être utilisée de sorte que la possibilité de contact humain lors d'un fonctionnement normal soit réduite. Afin d'éviter la possibilité de dépassement des restrictions de la FCC en matière d'exposition aux ondes radio, vous devez conserver une distance minimale de 20 cm entre vous (ou toute personne se trouvant à proximité) et l'antenne incorporée dans l'ordinateur. Des informations détaillées concernant les configurations autorisées sont disponibles sur <http://www.fcc.gov/> en entrant le numéro d'identification FCC de l'appareil.

Sécurité IC conformité

Canada, avis d'Industry Canada (IC)

ATTENTION:

- L'utilisation d'un réseau local sans fil conforme à la norme IEEE 802.11a limite l'emploi de ce produit à un usage en intérieur, du fait de son fonctionnement dans la bande de fréquences 5,15-5,25 GHz. Industrie Canada exige que ce produit soit utilisé en intérieur pour la bande de fréquences de 5,15-5,25 GHz, afin de réduire les possibilités d'interférences préjudiciables vers des systèmes mobiles par satellite. Un radar à haute puissance est désigné utilisateur principal des bandes 5,25-5,35 GHz et 5,65-5,85 GHz. Ces stations de radar peuvent causer des interférences et/ou des dommages à cet appareil.
- Le gain maximal de l'antenne alloué pour une utilisation avec cet appareil est de 6 dBi afin de se conformer à la limitation de puissance isotrope rayonnée équivalente (E.I.R.P) pour les bandes de fréquences 5,25-5,35 et 5,725-5,85 GHz pour une exploitation point à point.

Cet appareil numérique de Classe B est conforme aux normes ICES-003 et RSS-210.

Cet appareil est conforme au Cahier des charges sur les normes radioélectriques (RSS) de Industrie Canada relatif aux appareils exempts de licence. Son fonctionnement est soumis aux deux conditions suivantes: (1) cet appareil ne doit pas causer d'interférences, et (2) cet appareil doit accepter toute interférence, notamment les interférences qui peuvent affecter son fonctionnement.

Informations concernant l'exposition aux Fréquence Radio (RF)

La puissance de sortie émis par l'appareil de sans fil Extron est inférieure à la limite d'exposition aux fréquences radio d'Industry Canada (IC). Utilisez l'appareil de sans fil Extron de façon à minimiser les contacts humains lors du fonctionnement normale.

Extron Unit IC ID: IC: 10862A-EXT60150801

Déclaration d'antenne d'Industrie Canada (IC)

Conformément à la réglementation d'Industrie Canada, le présent émetteur radio peut fonctionner avec une antenne d'un type et d'un gain maximal (ou inférieur) approuvé pour l'émetteur par Industrie Canada. Dans le but de réduire les risques de brouillage radioélectrique à l'intention des autres utilisateurs, il faut choisir le type d'antenne et son gain de sorte que la puissance isotrope rayonnée équivalente (p.i.r.e.) ne dépasse pas l'intensité nécessaire à l'établissement d'une communication satisfaisante.

Le présent émetteur radio (IC:10862A-EXT60150801) a été approuvé par Industrie Canada pour fonctionner avec les types d'antenne énumérés ci-dessous et ayant un gain admissible maximal et l'impédance requise pour chaque type d'antenne. Les types d'antenne non inclus dans cette liste, ou dont le gain est supérieur au gain maximal indiqué, sont strictement interdits pour l'exploitation de l'émetteur.

Type: Dipole

Gain maximum: 2 dBi

Impédance: 50 Ohm

European Union

La basse fréquence 5,15-5,35 GHz est réservée à un usage en intérieur.

Conventions Used in this Guide

Notifications

The following notifications are used in this guide:

CAUTION: Risk of minor personal injury.

ATTENTION : Risque de blessure mineure.

ATTENTION:

- Risk of property damage.
- Risque de dommages matériels.

NOTE: A note draws attention to important information.

Specifications Availability

Product specifications are available on the Extron website, www.extron.com.

Contents

Introduction.....	1
About this Guide.....	1
About the eLink 100 Transmitter and Receiver....	1
Features	2
Application Diagram	3

Installation.....	4
Before Getting Started.....	4
Front and Side Panel Features and Connections.....	5
Transmitter Connections	5
Receiver Connections.....	6
Installing the Plug on the Power Supply	7
The eLink 100 On-Screen Display.....	8
Top Panel Features and Functions	8
Transmitter Buttons and LEDs	8
Receiver Buttons and LEDs.....	9

Operation.....	10
Operating Modes.....	10
Registering the Transmitter with the Receiver....	10
Registering Using the Remote Control	10
Registering Using the Register Buttons.....	11
Registering an Additional Receiver	11
Using the Remote Control and the OSD Menus.....	12
Remote Control Buttons	12
Using the Setup Menu	13

Reference Information	15
Mounting the Transmitter and Receiver.....	15
Best Practices for eLink 100 Mounting Locations	17
Resolutions and Rates.....	18
Operating Frequencies	19
Troubleshooting.....	20

Introduction

- [About this Guide](#)
- [About the eLink 100 Transmitter and Receiver](#)
- [Features](#)
- [Application Diagram](#)

About this Guide

This guide describes how to install, operate, and configure the Extron eLink 100 wireless extender for High Definition Multimedia Interface (HDMI) signals. The eLink 100 extender consists of the eLink 100 T transmitter and the eLink 100 R receiver (sold separately).

About the eLink 100 Transmitter and Receiver

The eLink 100 transmitter and receiver pair uses multi-input and multi-output (MIMO) wireless communication technology to transmit HDMI video and multi-channel embedded audio. This HDCP-compliant extender can send computer video resolutions up to 1920x1080, including HDTV 1080p @ 60 Hz, with less than 1 ms required to process the video signal (latency). AES-128 encryption provides a secure link to send signals up to 100 feet (30 meters).

The eLink 100 T transmitter uses the 5 GHz spectrum to transmit signals. In addition to point-to-point applications, one transmitter can be linked with up to four eLink 100 R receivers, allowing a single source such as a digital signage player to support multiple displays.

The transmitter and receiver are wirelessly compatible only with each other, but they can wirelessly extend any Extron product that has HDMI connectivity, including switchers and scalers. The transmitter can be connected to any Extron HDMI output with a signal up to 1080p @ 60 Hz. The receiver can be connected to any Extron HDMI input.

NOTE: If using the eLink 100 as an extender to a switcher output, select a switcher with an integrated scaler or signal processor for fastest switch times (see www.extron.com for switcher part numbers).

The eLink 100 is ideal for use in professional AV environments such as presentation spaces, rental and staging, and digital signage.

Features

- **Input** — HDMI connector on eLink 100 T transmitter
- **Output** — HDMI connector on eLink 100 R receiver
- **Transmits HDMI video and multi-channel audio signals wirelessly up to 100 feet (30 meters) in professional AV environments.**
- **Transmission through common obstacles** — The eLink 100 wireless extender works in the 5 GHz spectrum to allow for broad coverage and transmission through walls and furniture. Line-of-sight is not required but can maximize range.
- **Resolutions and rates** — Supports computer video up to 1920x1080, including HDTV 1080p @ 60 Hz (see the [Resolutions and Rates](#) table on page 18).
- **On-screen display (OSD)** — The OSD provides an interface for simplified setup and configuration.
- **IR remote control** — The eLink IR remote control, included with the receiver, enables use of the OSD on the output screen for configuration and setup.
- **Power supplies** — Each unit includes an external 5 VDC power supply, which accepts 100 to 240 VAC, 50-60 Hz input. A DC-to-USB adapter is also provided with the receiver, enabling the power supply to power the receiver through its USB port.
- **AES 128 encryption** — Supports Advanced Encryption Standard (AES) 128 data encryption standard.
- **HDMI features** — Supported HDMI specification features include data rates up to 6.75 Gbps, Deep Color up to 12-bit, 3D, and multi-channel audio formats.
- **HDCP compliant**
- **Ultra-low latency** — Less than one millisecond of latency in transmission of video and audio signals
- **Dynamic Frequency Selection (DFS)** —
 - Actively monitors the radio frequency (RF) spectrum to select the most appropriate frequencies, and prevents interference from other devices operating in the spectrum.
 - Takes advantage of DFS frequencies that are reserved for radar and weather purposes (see the [Operating Frequencies](#) table on page 19 for more information).
- **Embedded audio** — Compatible with a broad range of multi-channel audio signals, providing reliable operation with HDMI devices and surround sound systems.
- **MIMO (multi-input and multi-output)** — MIMO technology ensures that wireless connections are stable and function in environments with multipath signals.
- **Wireless transmission to as many as four receivers** — The transmitter can support up to four receivers, allowing a single source such as a digital signage player to support multiple displays.

Application Diagram

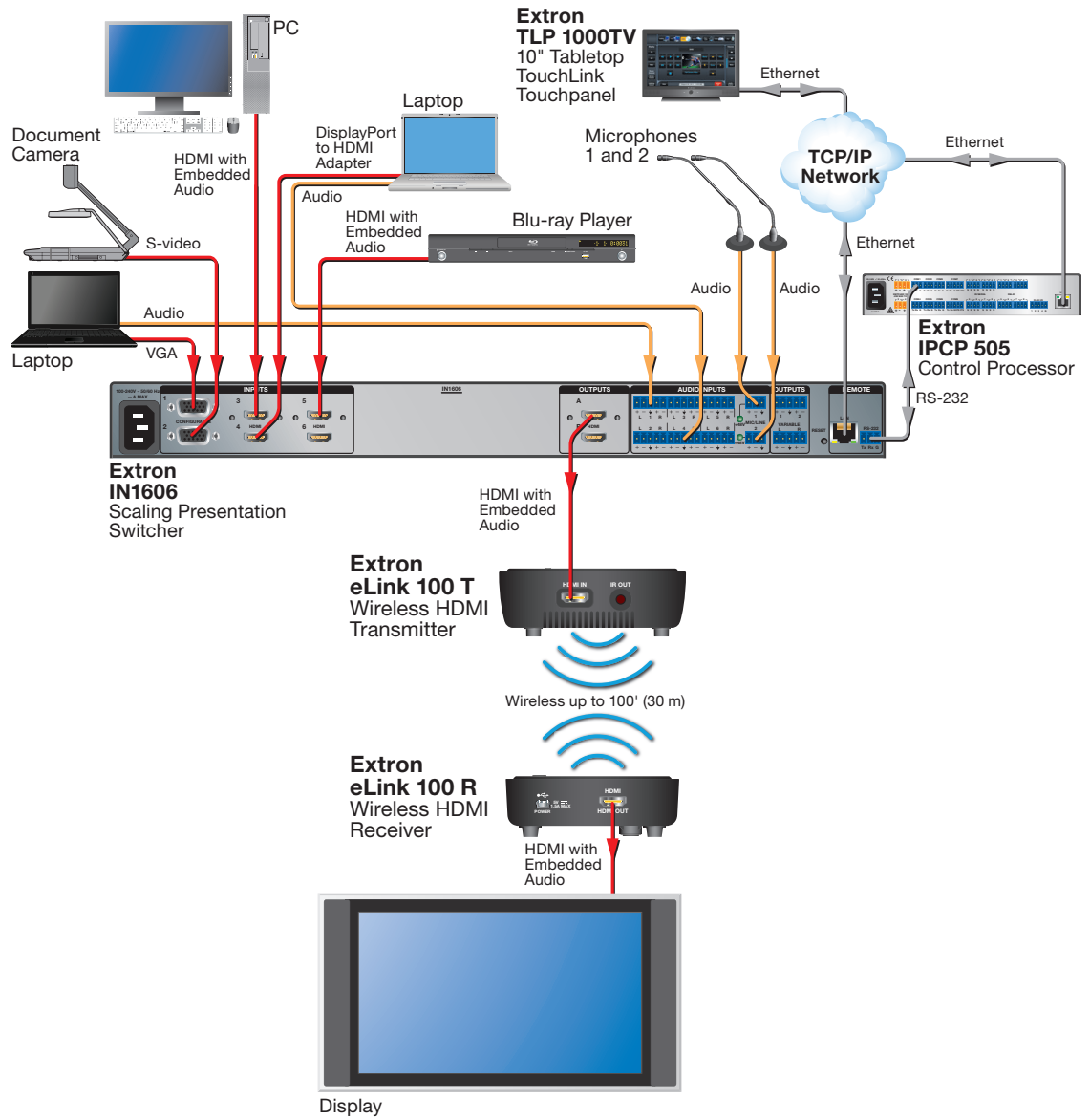

Figure 1. Example of an eLink 100 Transmitter and Receiver Application

Installation

This section provides instructions for installing the eLink 100 extender, including:

- [Before Getting Started](#)
- [Front and Side Panel Features and Connections](#)
- [Installing the Plug on the Power Supply](#)
- [The eLink 100 On-Screen Display](#)
- [Top Panel Features and Functions](#)

Before Getting Started

If mounting is required before cabling and setting up the eLink 100 units, see [Mounting the Transmitter and Receiver](#) on page 15 for mounting instructions.

ATTENTION:

- Installation and service must be performed by authorized personnel only.
- L'installation et l'entretien doivent être effectués par le personnel autorisé uniquement.
- These units are not suitable for use in air handling spaces.
- Ces unités ne sont pas appropriées pour une utilisation dans les espaces d'aération.

NOTE: For best performance:

- Ensure that the installation location is suitable for good signal transmission.
- For optimal signal range, avoid obstructions, such as walls, furniture or rack enclosures, between the transmitter and receiver locations. Denser wall materials can cause signal reduction.
- Maximum transmission distance is 100 feet (30 meters) with a clear line-of-sight.
- Up to four transmitter units can operate in the same room or environment. If a maximum of four transmitters is reached, the next group of units should be separated to prevent interference (see [Best Practices for eLink 100 Mounting Locations](#) on page 17).
- Maintain a distance of at least 6.5 feet (2 meters) between multiple eLink transmitters or multiple eLink receivers. Be mindful of units located beyond walls in adjacent rooms.
- Maintain a distance of at least 6.5 feet (2 meters) between the eLink 100 units and other 5 GHz RF devices. RF products can cause interference or traffic in the 5 GHz frequency band. Monitor the 5 GHz frequency band and plan systems to avoid traffic.
- Do not block the eLink 100 air ventilation openings and ensure proper air ventilation around the units.
- Be careful when handling the eLink 100 units as they become hot during operation.
- Do not install above ceiling tiles. The eLink 100 is not UL Listed for use in plenum air handling spaces.

Front and Side Panel Features and Connections

Transmitter Connections

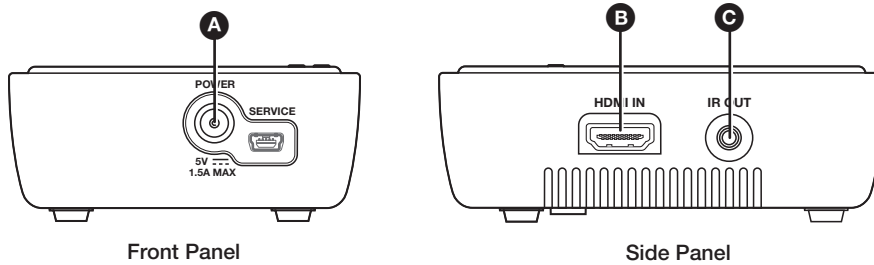

Figure 2. eLink 100 T Transmitter Side Panels

- A Power input connector** — Plug the external 5 VDC power supply into this 5 V jack to power the transmitter.

NOTES:

- Use only the power supply provided by Extron (see the **Attention** on page 7 for important information).
- The USB mini-B port to the right of this connector is reserved for use by Extron service personnel.
- See **Installing the Plug on the Power Supply** on page 7 if a different power supply plug is needed for your location.

- B HDMI In connector** — Connect an HDMI cable between this port and the HDMI output port of the digital video source device.
- C IR Out connector** — (Optional) Connect the tip-ring-sleeve end of the provided IR emitter to this IR Out connector. Use the included double-sided adhesive tape to attach the head of the IR emitter directly over the IR receiver window of the source device.

IR remote signals are passed from the receiver to the IR Out connector on the transmitter. This feature allows the user to point the remote control toward the receiver (by the display) instead of the source device, should the source device be in a different location.

NOTE: This feature also applies to applications with multiple receivers (see **Operating Modes** on page 10 for details on applications with more than one receiver). IR remote signals are passed from any of the registered receivers to the transmitter.

Receiver Connections

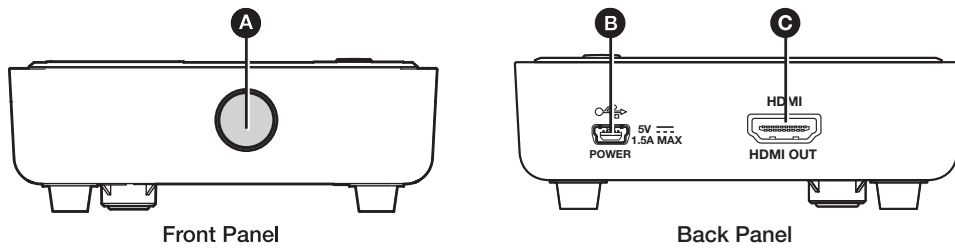

Figure 3. eLink 100 R Receiver Side Panel

- A IR sensor** — Receives IR commands from the included IR remote control unit and the IR remote of the source device.

NOTES:

- The IR sensor is compatible only with 38 kHz IR carrier frequency. See the specifications for the IR remote of the source device or contact the device manufacturer to verify the compatibility of the IR remote frequency.
- Make sure that the receiver IR sensor faces forward if using a source device IR remote to pass signals back to the transmitter. Wall mounting or concealing the receiver causes the IR sensor to be unreachable.

- B USB Power connector** — Connect the USB end of the provided 5 V jack-to-USB adapter to this USB mini-B connector. Connect the other end of the adapter to the provided 5 VDC power supply.

NOTE: Use only the power supply provided by Extron (see the **Attention** on the next page for important information).

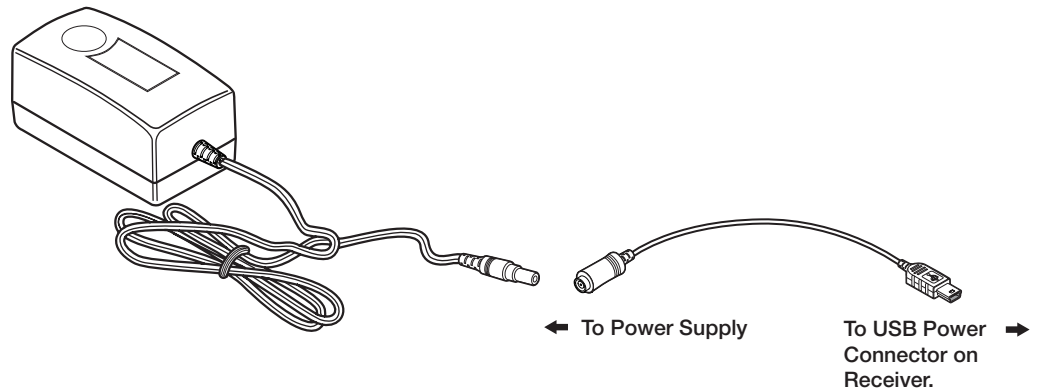

- C HDMI Out connector** — Connect an HDMI cable between this port and the HDMI input connector of the display device.

ATTENTION:

- This product is intended to be supplied by a Listed Power Unit marked “Class 2” or “LPS,” rated 5 VDC, 1.5 A minimum. Always use a power supply supplied by or specified by Extron. Use of an unauthorized power supply voids all regulatory compliance certification and may cause damage to the supply and the end product.
- Ce produit est destiné à une utilisation avec une source d'alimentation listée UL avec l'appellation « Classe 2 » ou « LPS » et normée 5 Vcc, 1,5 A minimum. Utilisez toujours les sources d'alimentation recommandées par Extron. L'utilisation d'une source d'alimentation non autorisée annule toute conformité réglementaire et peut endommager la source d'alimentation ainsi que le produit final.
- Unless otherwise stated, the AC/DC adapters are not suitable for use in air handling spaces or in wall cavities.
- Sauf mention contraire, les adaptateurs AC/DC ne sont pas appropriés pour une utilisation dans les espaces d'aération ou dans les cavités murales.
- The installation must always be in accordance with the applicable provisions of National Electrical Code ANSI/NFPA 70, article 725 and the Canadian Electrical Code part 1, section 16. The power supply shall not be permanently fixed to a building structure or similar structure.
- Cette installation doit toujours être en accord avec les mesures qui s'applique au National Electrical Code ANSI/NFPA 70, article 725, et au Canadian Electrical Code, partie 1, section 16. La source d'alimentation ne devra pas être fixée de façon permanente à une structure de bâtiment ou à une structure similaire.

Installing the Plug on the Power Supply

Each eLink 100 power supply kit contains a set of four plugs for use in different outlet types:

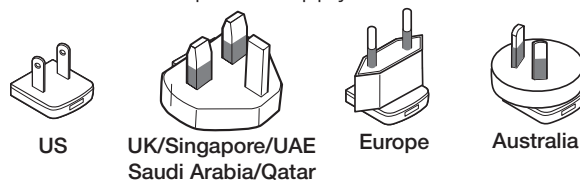

Figure 4. Included Power Supply Plugs

Select the appropriate plug for your location and follow the instructions below to install it on the power supply.

1. Slide the tab at the top of the power plug under the top edge of the recess in the power supply (see figure 5, ①).
2. Press down on the plug until it snaps into place in the power supply recess (②).

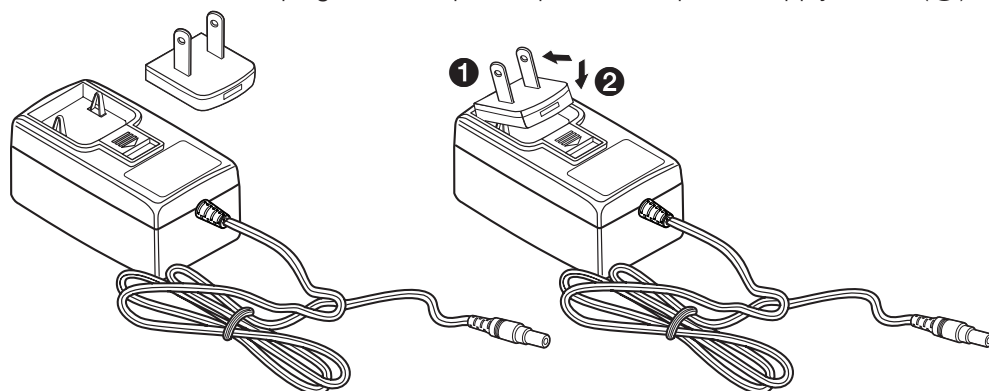

Figure 5. Inserting the Plug Into the eLink 100 Power Supply

To remove a power plug from the power supply, press downward on the latch (marked with an arrow) below the plug recess.

The eLink 100 On-Screen Display

When the receiver is powered and connected to the display device, the On-screen Display (OSD) appears (see the [Operation](#) section on page 10 for instructions on using the OSD).

Top Panel Features and Functions

The eLink 100 controls and indicators are located on the top panels of the transmitter and receiver.

Transmitter Buttons and LEDs

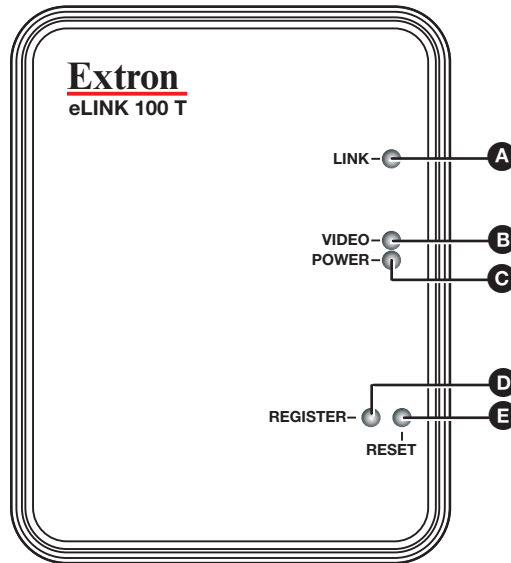

Figure 6. eLink 100 T Transmitter Top Panel

- A Link LED** — Blinks while the receiver is searching for a link to register with the transmitter (see [Registering the Transmitter with the Receiver](#) on page 10). When a link has been made, this LED lights steadily.
- B Video LED** — If the transmitter is registered with the receiver, this LED lights steadily when a valid source video format is detected and transmitted (see [Resolutions and Rates](#) table on page 18).
- C Power LED** — Lights steadily while power is connected to the transmitter.
- D Register button** — Hold this button after starting the registration process on the receiver (see [Registering the Transmitter with the Receiver](#) on page 10).
- E Reset button** — Press this button to reset the transmitter, if needed for troubleshooting (see [Troubleshooting](#) on page 20).

Receiver Buttons and LEDs

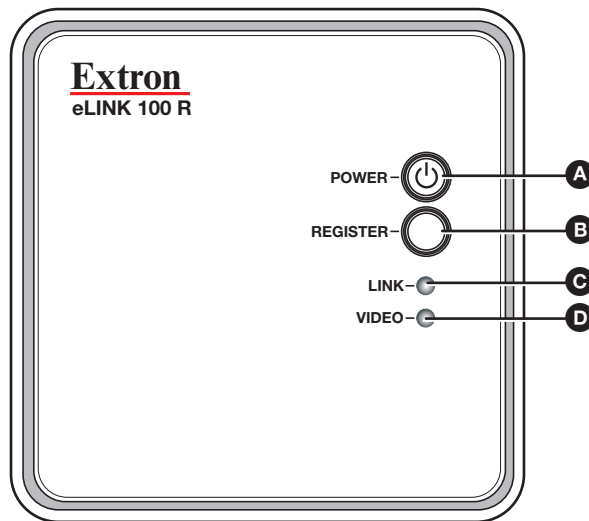

Figure 7. eLink 100 R Receiver Top Panel

- A Power button** — Hold this button to power on the eLink 100 receiver. The blue LED behind this button lights to indicate that power is on.

NOTE: By default, the blue LED in this button lights and the receiver is powered on when power is connected to the unit.

- B Register button** — Press this button to initiate the registration process between the receiver and transmitter (see [Registering the Transmitter with the Receiver](#) on the next page).
- C Link LED** — This blue LED blinks while the receiver is searching for a transmitter (see [Registering the Transmitter with the Receiver](#)). When a link has been made, this LED lights steadily.
- D Video LED** — This blue LED lights steadily when the transmitter and receiver are linked and a valid source video format is detected.

Operation

This section describes the operation of the eLink 100 extender, including:

- [Operating Modes](#)
- [Registering the Transmitter with the Receiver](#)
- [Using the Remote Control and the OSD Menus](#)

Operating Modes

The eLink 100 can operate in two modes:

- One transmitter linked with one receiver.
- One transmitter linked with up to four receivers.

NOTES:

- Up to four transmitter units can operate in the same room or environment. If a maximum of four transmitters is reached, the next group of units should be separated to prevent interference (see [Best Practices for eLink 100 Mounting Locations](#) on page 17).
- Maintain at least 6.5 feet (2 meters) between multiple eLink transmitters or multiple eLink receivers. Be mindful of units located beyond walls in adjacent rooms.

To establish communication between the eLink 100 transmitter and receiver, the transmitter must be registered with the receiver as explained below.

Registering the Transmitter with the Receiver

After registration is performed at the initial setup, the transmitter and receiver connect automatically when booted. Registration is not required again unless the transmitter is unregistered or removed from the receiver memory (see [Unregistering a transmitter](#) on page 14).

The units can be registered using the eLink 100 remote control (provided) or using the register buttons on the eLink 100 units.

Registering Using the Remote Control

NOTE: The remote control must be pointed at the IR sensor on the front panel of the receiver (see [figure 3](#), **A** on page 6) from a distance of no more than 30 feet (9.1 meters) and no more than 40° from center.

To register the transmitter with the receiver using the eLink 100 remote control:

1. Connect and apply power to the transmitter, input source, receiver, and output source.

NOTE: The registration process can be done without an input connected. In this case, a message on the OSD indicates that there is a missing video source.

2. Press the **Add** button on the remote control (see [figure 8](#), **G** on page 12). The following message appears on the OSD: **Please Activate Registration on Transmitter Unit.**

3. Press and hold the **Register** button (see [figure 6](#), **D** on page 8) on the transmitter top panel until the following message appears on the OSD: *Adding transmitter name. Press OK to continue or Exit to cancel.*
4. Press the **OK** button on the remote control (see [figure 8](#), **E** on page 12) to confirm. The message *Adding transmitter name...* and a progress bar appear on the OSD while the registration process is completing.

NOTE: Registration may take up to 60 seconds to complete. If the process is delayed more than 60 seconds, cycle power on both units, and then restart the registration process.

When registration is complete, the message and progress bar disappear from the display. The Link LED and the Video LED light steadily.

Registering Using the Register Buttons

To register the transmitter with a receiver **without** using the remote control:

1. Connect and apply power to the transmitter, input source, receiver, and output source.

NOTE: The registration process can be done without an input connected. In this case, a message on the OSD indicates that there is a missing video source.

Press and hold the **Register** button (see [figure 7](#), **B** on page 9) on the receiver top panel until the following message appears on the OSD: *Please Activate Registration on Transmitter Unit.*

Press and hold the **Register** button on the transmitter top panel (see [figure 6](#), **D**) until the following message appears on the OSD: *Adding transmitter name. Press OK to continue or Exit to cancel*

2. Press the **Register** button on the receiver to confirm. The message *Adding transmitter name...* and a progress bar appear on the OSD while the registration process is completing.

NOTE: Registration may take up to 60 seconds to complete. If the process is delayed more than 60 seconds, cycle power on both units, and then restart the registration process.

When registration is complete, the message and progress bar disappear from the display. The Link LED (see [figure 7](#), **C**) and the Video LED (**D**) light steadily.

Registering an Additional Receiver

To register an additional receiver with a transmitter:

1. Power down all receivers except the one being registered.
2. Perform steps 2 through 4 above for the preferred method of registering the receiver (using the remote control or using the register buttons).
3. When registration is complete, power on the other receivers. The video should be displayed on all monitors.

Using the Remote Control and the OSD Menus

Remote Control Buttons

Use the eLink 100 IR remote to control and navigate the OSD.

NOTE: The remote control must be pointed at the IR sensor on the front panel of the receiver (see [figure 3](#), **A**, on page 6) from a distance of no more than 30 feet (9.1 meters) and no more than 40° from center.

CAUTION:

- **Risk of explosion.** Do not replace the battery with an incorrect type. Dispose of used batteries according to the instructions.
- **Risque d'explosion.** Ne pas remplacer la pile par le mauvais type de pile. Débarrassez-vous des piles usagées selon le mode d'emploi.

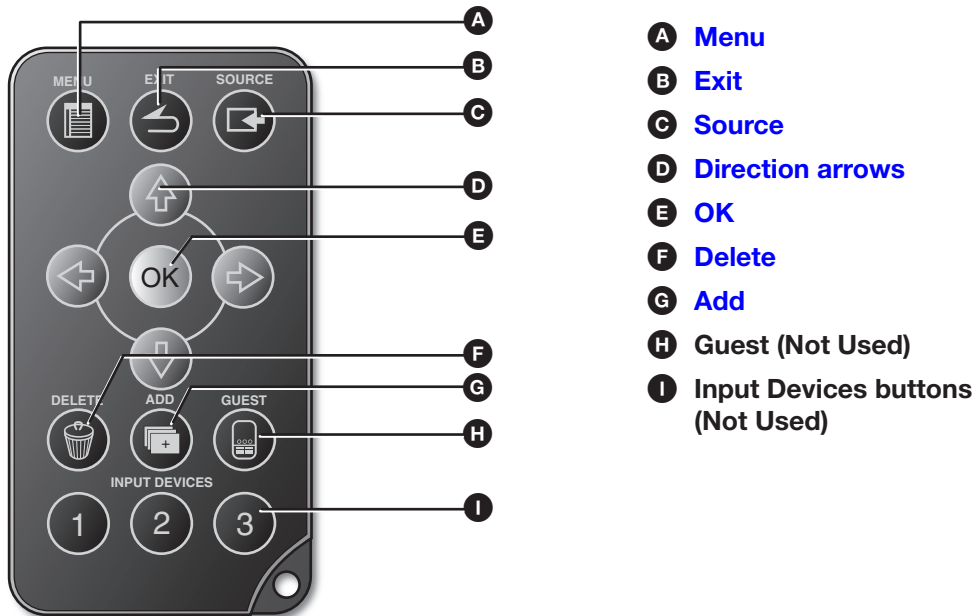

Figure 8. eLink 100 IR Remote Control

- A Menu** — Displays the OSD Setup menu (see [Using the Setup Menu](#) on the next page).
- B Exit** — Returns to the previous menu. If the Setup menu is displayed, pressing this button closes the OSD.
- C Source** — Displays the Select Video Source menu, which lists the transmitter that is registered to the receiver.

NOTE: The eLink 100 does not support applications with multiple transmitters to one receiver. Only one transmitter should be used with as many as four receivers.

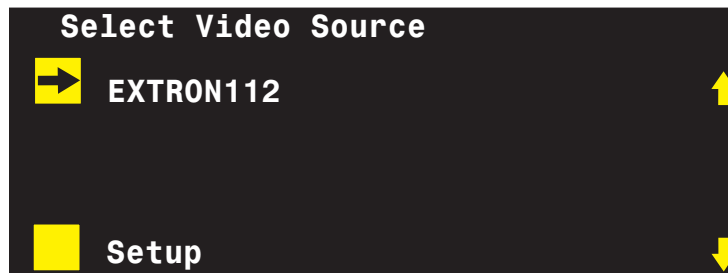

Figure 9. Select Video Source

- D Direction arrows** — The up and down arrow buttons scroll through menu items. The right and left arrow buttons select characters when changing a video source name (see [Modifying a video source name](#) on the next page).

NOTE: In the OSD screen, the yellow arrows on the right (see [figure 9](#) on the previous page) indicate that there are additional menu items to scroll through.

- E OK** — Selects the menu item.
- F Delete** — Displays the Choose Source to Remove submenu (see [Unregistering a transmitter](#) on the next page). This menu may also be accessed from the Setup menu by selecting **Remove Video Source**.
- G Add** — Begins the registration process (see [Registering the Transmitter with the Receiver](#) on page 10).

Using the Setup Menu

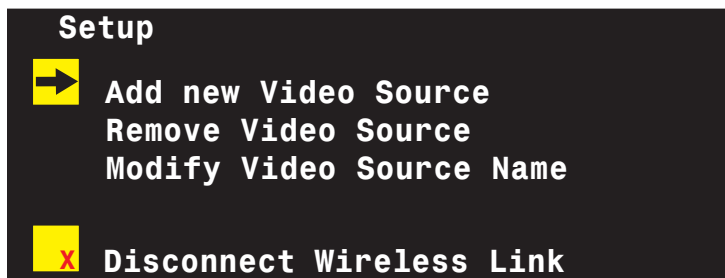

Figure 10. Setup Menu

The Setup menu includes the following options:

- **Add new Video Source** — Select this option to register the transmitter with a receiver. The message **Please Activate Registration on Transmitter Unit** appears (see [Registering the Transmitter with the Receiver](#) on page 10 for the rest of the registration procedure)
- **Remove Video Source** — Select this option to unregister a transmitter (see [Unregistering a transmitter](#) on the next page).
- **Modify Video Source Name** — Select this option to edit the name of an existing video source (see [Modifying a video source name](#) on the next page).
- **Disconnect Wireless Link** — This appears on the menu only if the source is displayed. Select this option to remove the connection between the source and the display.

Unregistering a transmitter

To unregister a transmitter (remove a video source) from a receiver:

1. Power on the receiver.
2. From the Setup menu, select **Remove Video Source**. This opens the Choose Source to Remove menu.

NOTE: Alternatively, you may press the **Delete** button on the remote control to access this menu.

3. From the Choose Source to Remove menu, select the name of the source to be unregistered.

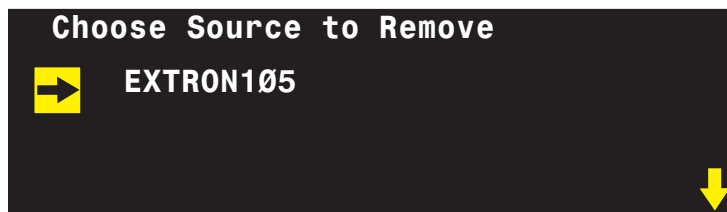

Figure 11. Choose Source to Remove OSD Menu

4. The message Removing transmitter name. Press OK to continue or Exit to Cancel is displayed. Press the **OK** button again to delete the source. (To stop the removal procedure, press the **Exit** button.)

NOTE: While the transmitter is being unregistered, the message Removing transmitter name... is displayed. After approximately 30 seconds, the OSD closes, indicating the source has been removed and the transmitter unregistered.

Modifying a video source name

To change the name of a video source:

1. Press the **Menu** button on the remote control to display the **Setup** menu.
2. From the **Setup** menu, select **Modify Video Source Name**.
3. From the **Choose Source to Rename** menu, select the source to be renamed. The **Rename Video Source Name** screen appears, displaying only the name to be changed.
4. Use the right and left arrow buttons on the remote control to move focus to the first character that you want to change.
5. Press the up or down arrow buttons repeatedly until the desired replacement letter or number is displayed.
 - To step through the alphabet in ascending (A-to-Z) order, use the up arrow. The down arrow moves through the alphabet in descending (Z-to-A) order.
 - When you scroll through the characters in ascending order, the OSD displays the letters of the uppercase alphabet, followed by the lowercase alphabet, then a space, then digits 0 through 9, after which the display cycles back through, starting with the uppercase letters. In descending order, this sequence is reversed.
6. Press the **OK** button. The **Select a Video Source** menu is displayed.
7. Select a source from the menu to display or press the **Exit** button to close the OSD.

Reference Information

This section includes the following reference information:

- [Mounting the Transmitter and Receiver](#)
- [Resolutions and Rates](#)
- [Operating Frequencies](#)
- [Troubleshooting](#)

Mounting the Transmitter and Receiver

ATTENTION:

- Installation and service must be performed by authorized personnel only.
- L'installation et l'entretien doivent être effectués par le personnel autorisé uniquement.

NOTE: Before mounting, see [Best Practices for eLink 100 Mounting Locations](#) on page 17.

The eLink 100 units can be placed on a table or mounted to a wall. For the transmitter and receiver to communicate, they must be no further than 100 feet (30 meters) apart with a clear line of sight.

To mount the transmitter or receiver to a wall or furniture:

1. Print and cut out the template for the unit to be mounted (cutout templates are available at www.extron.com).
2. Tape the template to the wall at the desired location.
3. Mark the location of the mounting hole centers on the wall or furniture (see figure 12).

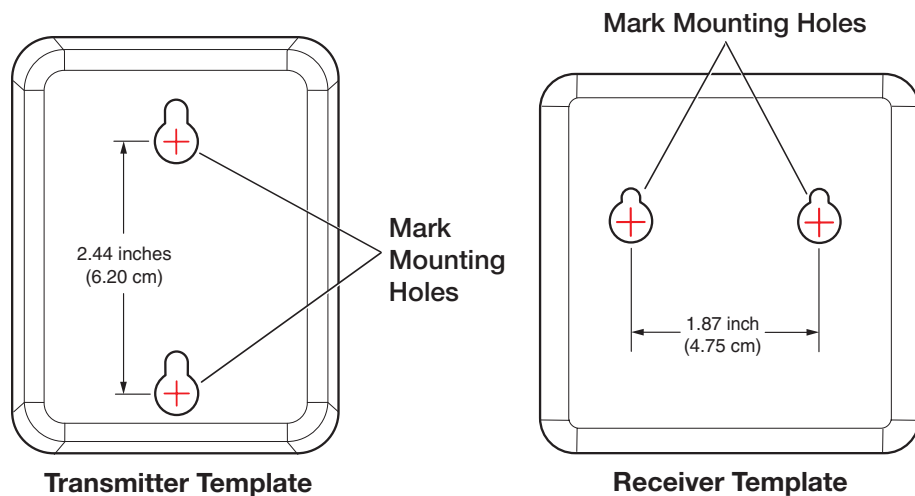

Figure 12. Mark the Center of the Two Mounting Hole Circles

4. Remove the template from the wall.

5. Drive two screws into the marked locations (see figure 13 for screw sizes).

NOTES:

- If drilling pilot holes, ensure that the size of the pilot holes is appropriate for the mounting screws used.
- Wall anchors may be required depending on wall material and stud locations.

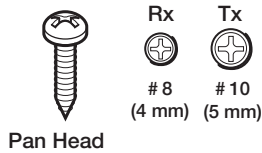
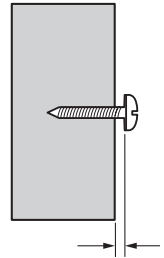

Figure 13. Screw Sizes for the eLink 100 Transmitter (Tx) and Receiver (Rx)

NOTE: Choice of screw length depends on wall or furniture thickness.

6. Tighten the screws until the screw heads protrude from the wall at the following distances:
- Transmitter: approximately 3/16 inch (4.7 mm)
 - Receiver: approximately 1/4 inch (6.4 mm)

If necessary, adjust the screw protrusion so that the eLink 100 unit is firmly secured on the wall or furniture surface.



7. Align the mounting holes on the back panel of the unit with the two screws protruding from the wall (see figure 14).

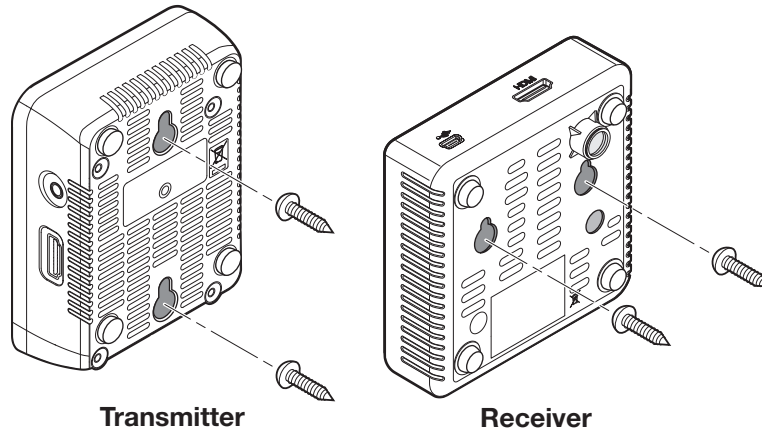

Figure 14. Mounting the eLink 100 Units

8. Slide the unit downward until both screws are seated in the narrow parts of the two keyholes.

Best Practices for eLink 100 Mounting Locations

For transmitter-to-receiver applications (one transmitter linked with up to four receivers):

- Ensure that the receivers are within a 100 foot (30 meter) radius of the transmitter with a clear line-of-sight (see figure 15).
- Maintain a distance of at least 6.5 feet (2 meters) between the eLink 100 transmitter and receiver.

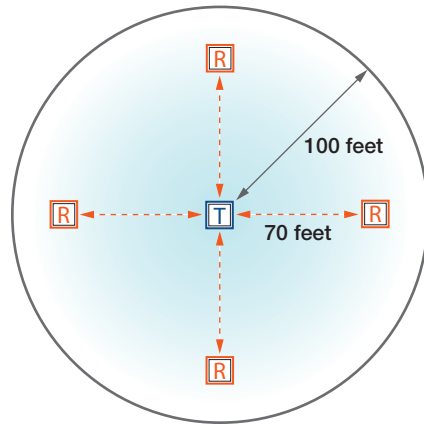

Figure 15. One-to-Four Application

For applications involving several transmitter-receiver pairs:

- Up to four transmitter units can operate in the same room or environment. If a maximum of four transmitters is reached, the next group of units should be separated to prevent interference. Ensure that there is at least a 150 foot (45 meter) radius around the outermost units in each group (see figure 16).
- Maintain a distance of at least 6.5 feet (2 meters) between individual eLink 100 transmitters and receivers. Be mindful of units located beyond walls in adjacent rooms.

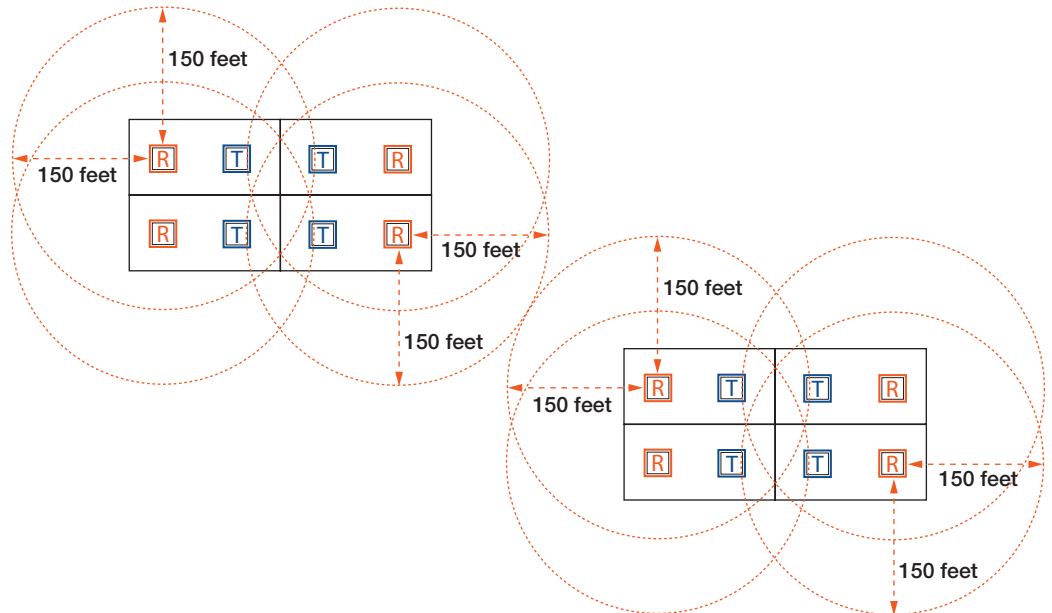

Figure 16. Application with Groups of eLink 100 Transmitter-Receiver Pairs

Resolutions and Rates

The following tables list the video and 3D resolutions and rates that the eLink 100 supports.

Format	Resolution	Refresh Rates in Hz									
		50 Hz	60 Hz	72 Hz	23.98 Hz	24 Hz	25 Hz	59.94 Hz	29.97 Hz	30 Hz	70 Hz
480i	720 (1440) x 480		X					X			
480p	640 x 480		X					X			
	720 x 480		X					X			
576i	720 (1440) x 576	X									
576p	720 x 576	X									
720p	1280 x 720	X	X					X			
1080i	1920 x 1080	X	X					X			
1080p	1920 x 1080	X	X		X	X	X	X	X	X	
VGA	640 x 480			X				X			
SVGA	800 x 600		X	X							
XGA	1024 x 768		X								X
WXGA	1280 x 800		X								
WXGA	1366 x 768		X								
WXGA+	1440 x 900		X								
SXGA+	1400 x 1050		X								
	1600 x 900		X								
WSXGA+	1680 x 1050		X								
3D Rates											
720p	1280 x 720	X	X		X	X		X	X	X	
1080i	1920 x 1080	X	X					X			
1080p	1920 x 1080	X	X		X	X		X	X	X	

Operating Frequencies

The eLink 100 uses DFS (Dynamic Frequency Selection) technology, which actively monitors the RF spectrum to select the most appropriate frequencies. This prevents interference from other devices operating in the 5 GHz spectrum.

For reference, the table below lists the operating frequencies and their range (DFS or Non-DFS).

Frequency (MHz)	Range	Regions		
		US/Canada/South Africa	Europe/Hong Kong/Singapore/UAE/Saudi Arabia/Qatar	Australia
5190	Non-DFS	X	X	X
5230		X	X	X
5270	DFS	X	X	X
5310		X	X	X
5510		X	X	X
5550		X	X	X
5590			X	
5630			X	
5670		X	X	X
5755	Non-DFS	X		
5795		X		

NOTES:

- Up to four transmitter units can operate in the same room or environment. Each transmitter unit occupies one of these frequencies.
- If a maximum of four transmitters is reached, the next group of units should be separated to prevent interference (see [Best Practices for eLink 100 Mounting Locations](#) on page 17).
- Some Wi-Fi routers and access points also use the 5 GHz frequency band. Monitor the 5 GHz frequency usage between these products and multiple eLink 100 units, and plan systems to avoid interference.

Troubleshooting

The following table gives recommended actions to solve problems that may occur during setup or operation. If the problem persists after performing the recommended action, contact Extron S3 Support.

Problem	Actions
Registration failure	Ensure that both the transmitter and receiver are powered on.
	Ensure that the paired units are the only Extron devices currently powered on.
	Ensure that the transmitter and receiver are no closer than 6.5 feet (2 meters) from each other.
	Keep the number of walls and obstructions between the transmitter and receiver to a minimum.
	Reduce distance between the transmitter and receiver.
No signal on display	Ensure that the receiver is powered on.
	Ensure that the display is powered on.
	Ensure that the receiver is properly connected to the display.
	Ensure that the display is set to display video from the correct source (HDMI1, HDMI2, and so on).
	Disconnect, then reconnect the HDMI cable between the receiver and the display.
	Replace the HDMI cable.
	Ensure that the video resolution is supported by the display.
	Power cycle the receiver and transmitter units. You may also reset the transmitter using the Reset button (see figure 6, E on page 8)
No video over the wireless link	Ensure that the transmitter is properly connected to the source.
	Ensure that the Link LED is lit.
	Ensure that the source device is powered on.
	Disconnect, then reconnect the HDMI cable between the transmitter and the source.
Abnormal color or noise on the display	Disconnect, then reconnect the HDMI cable between the receiver and the display.
	Disconnect, then reconnect the HDMI cable between the transmitter and the source.
	Place the transmitter and receiver closer together, but no closer than 6.5 feet (2 meters).
	Keep the number of solid walls between the transmitter and receiver to a minimum.
	Cycle power to the system.
	Power cycle the receiver and transmitter units. You can also reset the transmitter using the Reset button (see E on page 8)
No audio	Check the mute and volume settings on the display.
	Check if the audio format setting on the source is incompatible with the eLink system.

Problem	Actions
IR remote control malfunctions	Ensure that the clear plastic film covering the battery contacts is removed before using the IR remote.
	Ensure that the remote control batteries are fully charged.
	Ensure that there is enough distance between the receiver IR sensor and any fluorescent lighting or radiation that could interfere with the IR signals.
A Searching... message displays, and the Link LED blinks continuously.	The eLink 100 can take up to 60 seconds to establish a wireless link. If the link is not established within that time, verify that the transmitter is powered on and not connected to another receiver.
The message Connected to source name, please check video source is displayed.	Check the HDMI connection between the transmitter and the video source.
A connection failure message appears, followed by the message Wireless Off.	If more than one registered transmitter is present and the receiver fails to connect to a transmitter within one to two minutes, the receiver goes into standby mode and shuts down the radio frequency. To connect to the desired source, press the Source button on the remote control and select the desired source from the OSD menu.
The Link LED blinks rapidly and there is no video on the display.	Cycle power to the unit. If the problem persists, contact the Extron S3 Sales and Technical Support Hotline.
	Power cycle the receiver and transmitter units. You may also reset the transmitter using the Reset button (see figure 6, E on page 8).
A link cannot be established, or audio or video quality is poor.	Decrease the distance between the transmitter and receiver and remove any obstacles between them.
The message Please wait, this action may take up to 60 sec" appears for more than 60 seconds.	This message may appear during registration process. If this message appears for more than 60 seconds, cycle power on both units, then restart the registration process.
	Power cycle the receiver and transmitter units. You may also reset the transmitter using the Reset button (see E on page 8)

Extron Warranty

Extron Electronics warrants this product against defects in materials and workmanship for a period of three years from the date of purchase. In the event of malfunction during the warranty period attributable directly to faulty workmanship and/or materials, Extron Electronics will, at its option, repair or replace said products or components, to whatever extent it shall deem necessary to restore said product to proper operating condition, provided that it is returned within the warranty period, with proof of purchase and description of malfunction to:

USA, Canada, South America, and Central America:

Extron Electronics
1230 South Lewis Street
Anaheim, CA 92805
U.S.A.

Japan:

Extron Electronics, Japan
Kyodo Building, 16 Ichibancho
Chiyoda-ku, Tokyo 102-0082
Japan

Europe and Africa:

Extron Europe
Hanzeboulevard 10
3825 PH Amersfoort
The Netherlands

China:

Extron China
686 Ronghua Road
Songjiang District
Shanghai 201611
China

Asia:

Extron Asia Pte Ltd
135 Joo Seng Road, #04-01
PM Industrial Bldg.
Singapore 368363
Singapore

Middle East:

Extron Middle East
Dubai Airport Free Zone
F13, PO Box 293666
United Arab Emirates, Dubai

This Limited Warranty does not apply if the fault has been caused by misuse, improper handling care, electrical or mechanical abuse, abnormal operating conditions, or if modifications were made to the product that were not authorized by Extron.

NOTE: If a product is defective, please call Extron and ask for an Application Engineer to receive an RA (Return Authorization) number. This will begin the repair process.

USA: 714.491.1500 or 800.633.9876

Asia: 65.6383.4400

Europe: 31.33.453.4040

Japan: 81.3.3511.7655

Units must be returned insured, with shipping charges prepaid. If not insured, you assume the risk of loss or damage during shipment. Returned units must include the serial number and a description of the problem, as well as the name of the person to contact in case there are any questions.

Extron Electronics makes no further warranties either expressed or implied with respect to the product and its quality, performance, merchantability, or fitness for any particular use. In no event will Extron Electronics be liable for direct, indirect, or consequential damages resulting from any defect in this product even if Extron Electronics has been advised of such damage.

Please note that laws vary from state to state and country to country, and that some provisions of this warranty may not apply to you.