

5XT

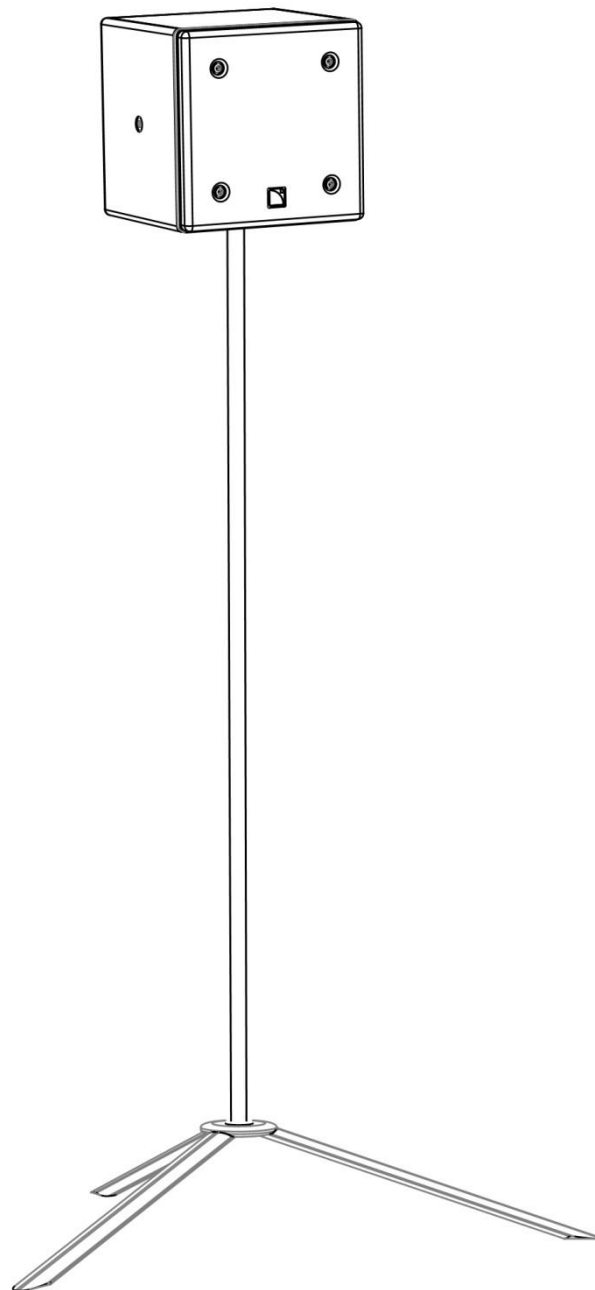

rigging manual (EN)

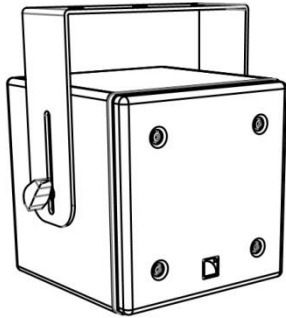

5XT COAXIAL ENCLOSURE

RIGGING MANUAL

VERSION 4.0

Document reference: 5XT_RM_EN_4.0

Distribution date: March 30, 2017

© 2017 L-ACOUSTICS®. All rights reserved.

**No part of this publication may be reproduced or transmitted in any form
or by any means without the express written consent of the publisher.**

SAFETY INSTRUCTIONS

1. **Read this manual**
2. **Follow all SAFETY INSTRUCTIONS as well as DANGER and OBLIGATION warnings**
3. **Never incorporate equipment or accessories not approved by L-ACOUSTICS®**
4. **Read all the related PRODUCT INFORMATION documents before exploiting the system**
The product information document is included in the shipping carton of the related system component.
5. **Work with qualified personnel for rigging the system**
Installation should only be carried out by qualified personnel that are familiar with the rigging techniques and safety recommendations outlined in this manual.
6. **Ensure personnel health and safety**
During installation and set-up personnel must wear protective headgear and footwear at all times. Under no circumstances personnel is allowed to climb on a loudspeaker assembly.
7. **Respect the Working Load Limit (WLL) of third party equipment**
L-ACOUSTICS® is not responsible for any rigging equipment and accessories provided by third party manufacturers. Verify that the Working Load Limit (WLL) of the suspension points, chain hoists and all additional hardware rigging accessories is respected.
8. **Respect the maximum configurations and the recommended safety level**
For safety issue, respect the maximum configurations outlined in this manual. To check the conformity of any configuration in regards with the safety level recommended by L-ACOUSTICS®, model the system in SOUNDVISION and refer to the warnings in **Mechanical Data** section.
9. **Be cautious when flying a loudspeaker array**
Always verify that no one is standing underneath the loudspeaker array when it is being raised. As the array is being raised, check each individual element to make sure that it is securely fastened to the adjacent element. Never leave the array unattended during the installation process. As a general rule, L-ACOUSTICS® recommends the use of safety slings at all times.
10. **Be cautious when ground-stacking a loudspeaker array**
Do not stack the loudspeaker array on unstable ground or surface. If the array is stacked on a structure, platform, or stage, always check that the latter can support the total weight of the array. As a general rule, L-ACOUSTICS® recommends the use of safety straps at all times.
11. **Take into account the wind effects on dynamic load**
When a loudspeaker assembly is deployed in an open air environment, wind can produce dynamic stress to the rigging components and suspension points. If the wind force exceeds 6 bft (Beaufort scale), lower down and/or secure the loudspeaker array.

SYMBOLS

The following symbols are used in this document:



DANGER

This symbol indicates a potential risk of harm to an individual or damage to the product. It can also notify the user about instructions that must be strictly followed to ensure safe installation or operation of the product.



OBLIGATION

This symbol notifies the user about instructions that must be strictly followed to ensure proper installation or operation of the product.



EQUIPMENT

This symbol indicates the equipment, tools, and spare parts required to perform a procedure.



INFORMATION

This symbol notifies the user about complementary information or optional instructions.

5XT COAXIAL ENCLOSURE

RIGGING MANUAL

VERSION 4.0

WELCOME TO L-ACOUSTICS®

Thank you for choosing the L-ACOUSTICS® 5XT coaxial enclosure.

This document contains essential information on rigging the system properly and safely. Carefully read this document in order to become familiar with these procedures.

As part of a continuous evolution of techniques and standards, L-ACOUSTICS® reserves the right to change the specifications of its products and the content of its documents without prior notice.

Please check the L-ACOUSTICS® web site on a regular basis to download the latest document and software updates: www.l-acoustics.com.

CONTENTS

SAFETY INSTRUCTIONS	3
SYMBOLS	3
WELCOME TO L-ACOUSTICS®	4
CONTENTS	4
1 RIGGING SYSTEM	5
1.1 Loudspeaker enclosure	5
1.2 Rigging elements.....	5
2 MECHANICAL SAFETY	6
2.1 Maximum configurations	6
2.2 Assessing mechanical safety.....	6
3 SYSTEM SETUP	7
3.1 Flying.....	7
3.2 Pole-mounting.....	8
APPENDIX A: ETR5 STORAGE POSITION	9
APPENDIX B: SPECIFICATIONS	10

1 RIGGING SYSTEM

The system approach developed by L-ACOUSTICS® consists in providing packaged solutions for loudspeaker systems in order to guarantee the highest and most predictable level of performance at any step: modeling, installation, and operation. An L-ACOUSTICS® loudspeaker system is the set of components available to form any loudspeaker system based on one of the full-range loudspeaker enclosures afforded by L-ACOUSTICS®. It includes enclosures, rigging accessories, loudspeaker cables, amplified controllers and software applications.

The main components involved in the **5XT** rigging process are the following:

1.1 Loudspeaker enclosure

- 5XT Coaxial enclosure.
Equipped with two M6 inserts and one 3/8" microphone-stand insert.



Loudspeaker system design

Sound design aspects are beyond the scope of this document. However, the various applications of the system will be based on the operating modes presented in this document.

1.2 Rigging elements

- ETR5 U-bracket used to fly the 5XT.



Other 5XT SYSTEM components

All the other components of the system are presented in the 5XT **user manual**, document intended to describe the enclosures operation and connection.



5XT

ETR5

Main components involved in the 5XT rigging process

2 MECHANICAL SAFETY

2.1 Maximum configurations

The 5XT rigging system complies with 2006/42/EC: Machinery Directive. It has been designed following the guidelines of BGV-C1.

2006/42/EC: Machinery Directive specifies a safety factor of 4:1 against the rupture. The deployments specified in this manual correspond to a safety factor of 5:1 or higher.



Mechanical safety of the rigging system

Before any installation, always model the system in SOUNDVISION and check the **Mechanical Data** section for any *stress warning* or *stability warning*.

2.2 Assessing mechanical safety

In order to assess the actual safety of any array configuration before implementation, refer to the following warnings:



Rated working load limit (WLL) is not enough

The rated WLL is an indication of the element resistance to tensile stress. For complex mechanical systems such as loudspeaker arrays, WLLs cannot be used per se to determine the maximum number of enclosures within an array or to assess the safety of a specific array configuration.



Mechanical modeling with SOUNDVISION

The working load applied to each linking point, along with the corresponding safety factor, will depend on numerous variables linked to the composition of the array (type and number of enclosures, splay angles) and the implementation of the flying or stacking structure (number and location of flying points, site angle). This cannot be determined without the complex mechanical modeling and calculation offered by SOUNDVISION



Assessing the safety with SOUNDVISION

The overall safety factor of a specific mechanical configuration always corresponds to the lowest safety factor among all the linking points. Always model the system configuration with the SOUNDVISION software and check the Mechanical Data section to identify the weakest link and its corresponding working load. By default, a *stress warning* will appear when the mechanical safety goes beyond the recommended safety level.



Safety of ground-stacked arrays in SOUNDVISION

For ground-stacked arrays, a distinct *stability warning* is implemented in SOUNDVISION. It indicates a tipping hazard when the array is not secured to the ground, stage or platform. It is user responsibility to secure the array and to ignore this warning.



Consideration must be given to unusual conditions

SOUNDVISION calculations are based on usual environmental conditions. A higher safety factor is recommended with factors such as extreme high or low temperatures, strong wind, prolonged exposition to salt water, etc. Always consult a rigging specialist to adopt safety practices adapted to such a situation.

3 SYSTEM SETUP

3.1 Flying

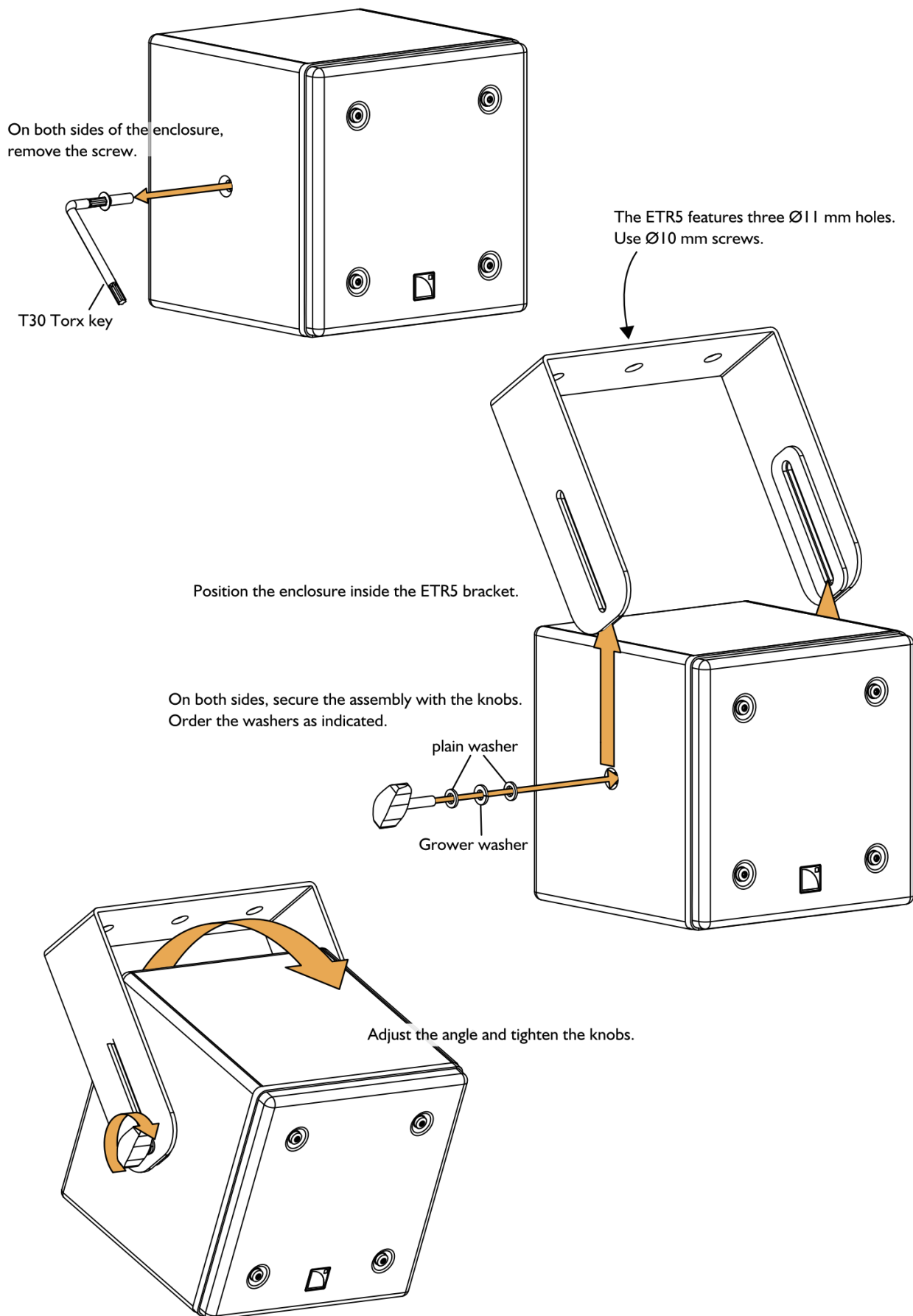

5XT COAXIAL ENCLOSURE

RIGGING MANUAL

VERSION 4.0

3.2 Pole-mounting



Risk of damaging the insert

Do not overtighten the screw.

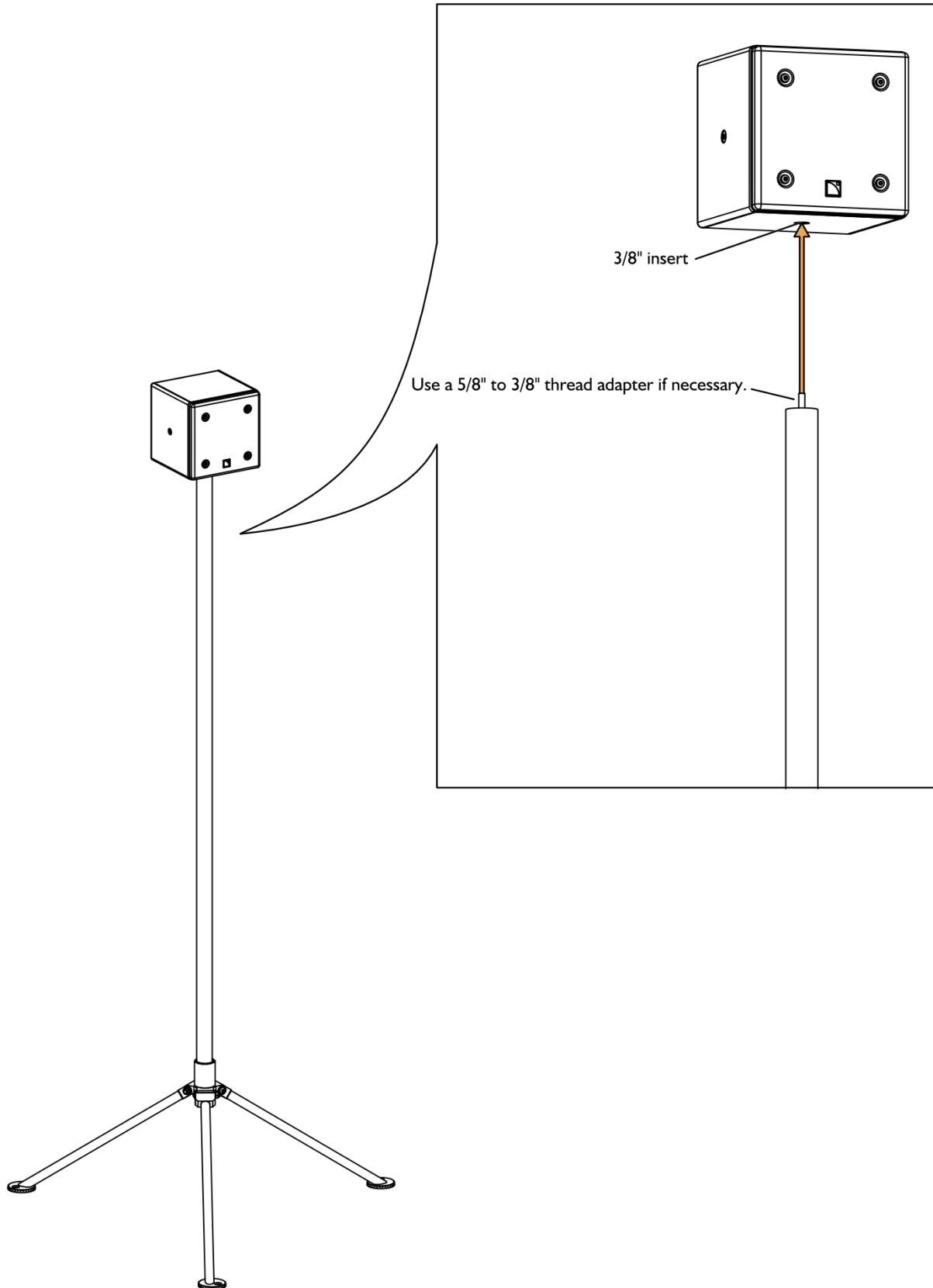

APPENDIX A: ETR5 STORAGE POSITION

When the 5XT is stored the ETR5 can be used to protect the connectors at the back of the enclosure as illustrated below.

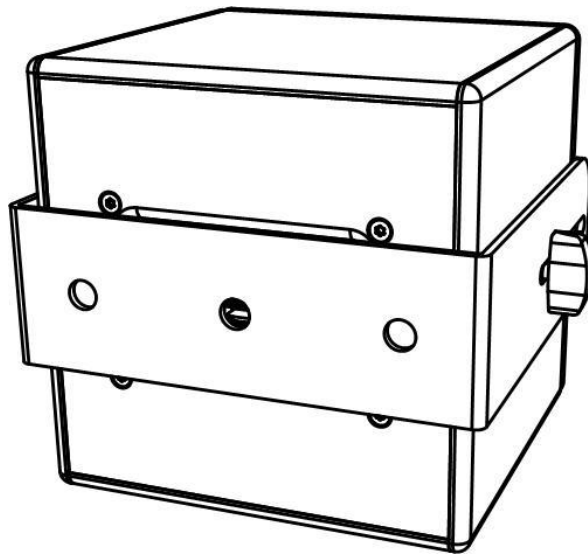

5XT COAXIAL ENCLOSURE

RIGGING MANUAL

VERSION 4.0

APPENDIX B: SPECIFICATIONS

5XT

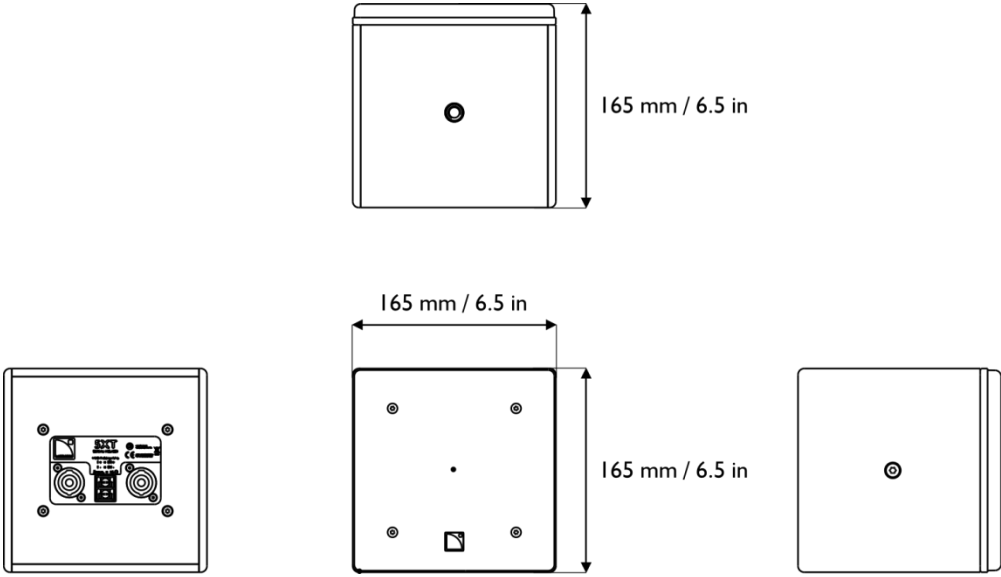
Description	2-way passive coaxial enclosure, amplified by LA4 / LA4X / LA8 / LA12X	
Usable bandwidth (-10 dB)	95 Hz – 20 kHz ([5XT] preset)	
Maximum SPL ¹	121 dB ([5XT] preset)	
Coverage angle (-6 dB)	110° axi-symmetric	
Transducers	LF: 1 × 5" weather resistant, bass-reflex HF: 1 × 1" diaphragm compression driver	
Nominal impedance	16 Ω	
RMS power handling	85 W	
Connectors	IN: 1 × 4-point SpeakON® LINK: 1 × 4-point SpeakON® IN/LINK: 2 × screw terminals	
Dimensions	 <p>The technical drawings show the enclosure from three perspectives: a top view, a front view, and a side view. The top view shows a square shape with a central dot and four small circles at the corners. The front view shows a square shape with a central dot and a small square at the bottom center. The side view shows a square shape with a central dot. All dimensions are indicated as 165 mm / 6.5 in.</p>	
Rigging components	1 × 3/8" insert for microphone stand 2 × M6 inserts for ETR5 U-bracket	
Physical data	W × H × D:	165 mm × 165 mm × 165 mm 6.5 in × 6.5 in × 6.5 in
	Weight (net):	3.5 kg / 7.7 lb
	Cabinet:	Baltic birch plywood
	Finish:	Dark grey Brown (Pantone 426C) Pure white (RAL 9010®) Custom RAL code on special order
	Rigging components and grill:	High strength steel with anti-corrosion coating

¹ Peak level measured at 1 m under free field conditions using pink noise with crest factor 4 (preset specified in brackets).

ETR5

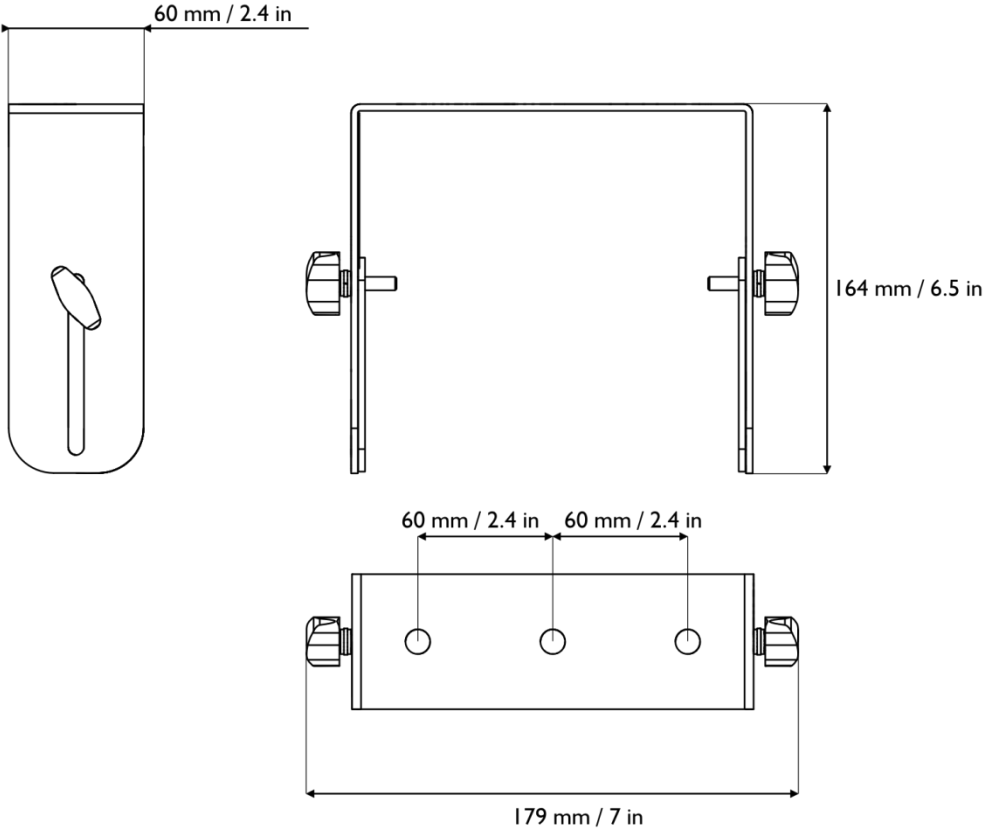
Description	U-bracket for 5XT enclosure		
Dimensions			
Weight	0.7 Kg / 1.55 lb	Material	High-grade steel with anti-corrosion coating.



L-Acoustics, an L-Group Company

13 rue Levacher Cintrat – 91460 Marcoussis – France
+33 1 69 63 69 63 – info@l-acoustics.com
www.l-acoustics.com

L-Acoustics GmbH

Steiermärker Str. 3-5
70469 Stuttgart
Germany
+49 7 11 89660 323

L-Acoustics Ltd.

PO. Box Adler Shine - Aston House
Cornwall Avenue - London N3 1LF
United Kingdom
+44 7224 11 234

L-Acoustics Inc.

2645 Townsgate Road, Suite 600
Westlake Village, CA 91361
USA
+1 805 604 0577



L-GROUP

www.l-group.com